31 FILTRATION

31.1	INTRODUCTION	31-1
31.2	BIOFILTRATION SWALE AND VEGETATED FILTER STRIP	31-1
31.2.1	Runoff Treatment And Conveyance.....	31-1
31.2.2	Biofiltration Swale Design	31-2
31.2.3	Vegetated Filter Strip Design	31-7
31.2.4	Maintenance	31-9
31.3	MEDIA FILTRATION.....	31-9
31.3.1	Features and Planning.....	31-9
31.3.2	Design Criteria	31-10
31.3.3	Construction and Maintenance Criteria	31-14
APPENDIX 31.A	WORKED EXAMPLE	31-15
31.A.1	Biofiltration Swale	31-15
31.A.2	Vegetated Filter Strips.....	31-19
31.A.3	Media Filtration	31-20

31.1 INTRODUCTION

The purpose of this chapter is to provide general and specific criteria for planning, design, construction and maintenance of biofiltration swales, vegetated filter strips and media filtration facilities.

The first two BMPs are biofiltration or plant/vegetation based runoff treatment methods while the latter, typically sand, is used to remove pollutants through media retention or adsorption process which are similar to infiltration method described in Chapter 21 and 32. Both biofilters and media filter design procedures are discussed in Sections 31.2 and 31.3.

31.2 BIOFILTRATION SWALE AND VEGETATED FILTER STRIP

Biofiltration swales and vegetated filter strips are two practices, which have been used for some years in most developed countries. Only fairly recently have they been studied to determine their effectiveness at treating pollution from stormwater runoff and to assess their abilities to reduce on-site peak flow rates. At this time these two practices are assumed to provide runoff quality treatment only.

The main purpose of these two main types of biofiltration BMPs is to remove low concentrations and quantities of TSS, heavy metals, hydrocarbons and nutrients from stormwater. The vegetated treatment systems (typically grass) remove pollutants by means of sedimentation, filtration, soil sorption, and/or plant uptake.

This section provides guidance on how they can be designed to accomplish one of the primary stormwater management objectives, runoff treatment. While quantity control is not generally provided by these BMPs, biofiltration swales can be designed to convey higher flows to BMPs used for quantity control and thus may be incorporated into the primary conveyance/detention system (see Chapter 26).

Section 31.2.1 should be read first as it gives a description of the pollutant removal mechanisms utilised by biofilters to meet runoff treatment standard. Sections 31.2.2 and 31.2.3 provide detailed design criteria, design procedure (sizing) and maintenance criteria for each BMP.

31.2.1 Runoff Treatment And Conveyance

(a) Overview

A biofiltration swale is a vegetated channel that is sloped like a standard storm drain channel; stormwater enters at one end and exits at the other with treatment provided as the runoff passes through the channel. With vegetated filter strips the flow is distributed broadly along the width of the vegetated area; treatment is provided as runoff travels as sheet flow through the vegetation. Which method to use depends upon the drainage patterns of the site. A vegetated strip would function well where the water can be spread along the length of a lot so that it travels across the vegetated strip as sheet flow. Figure 31.1 shows a typical application of swale and vegetated filter strips.

Biofiltration swales and vegetated filter strips are to be designed to treat the 3 month storm, as required (see Chapter 4).

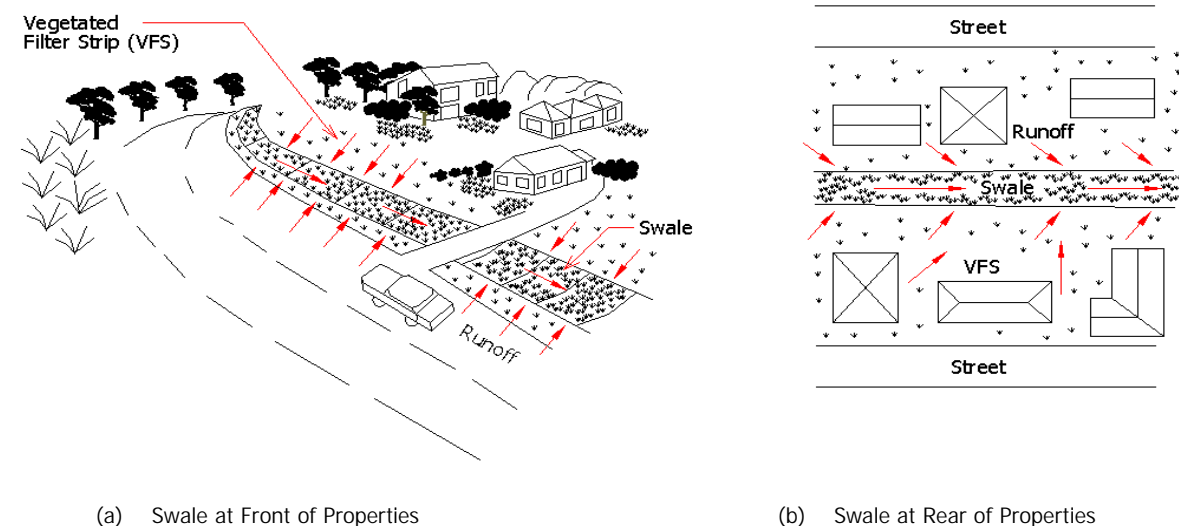

Figure 31.1 Typical Application of Swale and Vegetated Filter Strips

(b) Mechanisms of Pollutant Removal

Biofiltration swales and vegetated filter strips use similar pollutant removal mechanism, i.e., "biofiltration". The term "biofiltration" has been coined to describe the more-or-less simultaneous process of filtration, infiltration, adsorption and biological uptake of pollutants in stormwater that take place when runoff flows over and through vegetated treatment facilities. Vegetation growing in these facilities acts as both a physical filter which causes gravity settling of particulates by regulating velocity of flow and also as a biological sink when direct uptake of dissolved pollutants occurs.

Another means of removing pollutants occurs as the stormwater contacts the soil surface and infiltrates into the underlying soil. Dissolved pollutants are adsorbed onto soil particles. This is a potentially important removal mechanism for both dissolved heavy metals and phosphorus by undergoing ion exchange with elements in the soil. In addition, biological activity in the soil can metabolise organic contaminants. However, in highly porous soils stormwater can be a threat to shallow ground water since these soils have little treatment capacity. In such instances, biofilter BMPs must meet the General Limitations for infiltration BMPs (see Chapter 21) or it may be necessary to install a liner to prevent infiltration.

The degree to which the above mechanisms operate will vary considerably depending upon many variables such as:

- the depth and condition of the vegetation,
- the velocity of the flowing water,
- the slope of the ground, and
- the texture of the underlying soil.

However, the most important criterion that can be developed from these variables is the residence time of the stormwater in the biofilter, provided there is an adequate stand of vegetation and the underlying soil is of moderate texture. Therefore, to be effective, the biofilter must be designed such that the residence time is sufficient to permit most if not all of the particulates and at least some of the dissolved pollutants to be removed from the stormwater.

Design criteria that will maximise the effectiveness of biofiltration swales and strips are still in the development stage and research is required to support this application in Malaysia. They have been largely based on work done in developed countries.

31.2.2 Biofiltration Swale Design

A biofiltration swale is designed to treat conventional pollutants as well as nutrients. When used as a primary treatment, it should be located "off-line" from the primary conveyance/detention system in order to enhance

effectiveness and can be used to protect a water quality infiltration BMP or a sand media filtration BMP.

In cases where a biofiltration swale is located "on-line" it must be sized as both a treatment facility and as a conveyance system to pass the peak hydraulic flows of the 5 and 100 year design storms (Chapter 26). To be effective, the depth of the stormwater during treatment must not exceed the height of the grass.

(a) Design Criteria

The interim criteria have been selected to ensure that the velocity of water does not exceed 0.5 m/s along a swale of 60 m in length during the water quality design storm (3 month ARI). An additional requirement for swales designed to convey larger storms (up to the 100 year) is that the peak velocity for the maximum design storm is kept below erosive levels. Complete details of the criteria are given in Table 31.1 and the appendices give step-by-step procedures for designing biofiltration swales and vegetated filter strips including an example calculation.

(i) General Criteria

1. For biofiltration swale, it is important to maximise water contact with vegetation and the soil surface. Gravely and coarse sandy soils will not provide water quality treatment unless the bottom of the swale is lined to prevent infiltration (see Figure 31.2). (Note: sites that have relatively coarse soils may be more appropriate for stormwater quantity infiltration purposes after runoff treatment has been accomplished).
2. Select vegetation on the basis of pollution control objectives and according to what will best establish and survive in the site conditions. For general purposes, select fine, close-growing and flow resistant grasses. Alternatively, where some period of soil saturation is expected, where particular pollutant uptake characteristics are desired, or both, select emergent wetland plant species. Protect these plants from perdition during establishment by netting
3. Select a grass height of 150 mm or more and a flow depth of less than 150 mm for water quality design storm. Grasses over that height tend to flatten down when water is flowing over them, which prevents sedimentation. To attain this height requires regular maintenance.
4. The channel slope should normally be between 2 and 4%. A slope of less than 2% can be used if underdrains are placed beneath the channel to prevent ponding. For a slope of greater than 4%, use drop structures in the channel to reduce the longitudinal slope.

Table 31.1 Summarised Design Criteria for Biofiltration Swales and Vegetated Filter Strips

Design Parameter	Biofiltration Swales	Vegetated Filter Strip
Longitudinal slope	2% – 4% < 2% use underdrain > 4% use drop structure	1% – 15%
Maximum water depth	150 mm (water quality)	25 mm (water quality)
Manning coefficient of overland flow	0.1 (0.2 if mowed infrequently)	0.2 (0.35 if mowed to maintain grass height greater than 100 mm)
Bed width (bottom)	0.6 – 3 m	
Freeboard height	0.3 m	
Minimum hydraulic residence time minutes	2 minutes	5 minutes
Minimum length	60 m	Sufficient to achieve hydraulic residence time
Maximum side slope	3H : 1V 4H : 1V (preferred)	
Maximum distance for each drop structure	15 m apart	
Maximum drainage flowpath		50 m
Maximum longitudinal slope of contributing area		10% (steeper than 10% need upslope flow spreading and energy dissipation)
Maximum lateral slope of contributing area		2%

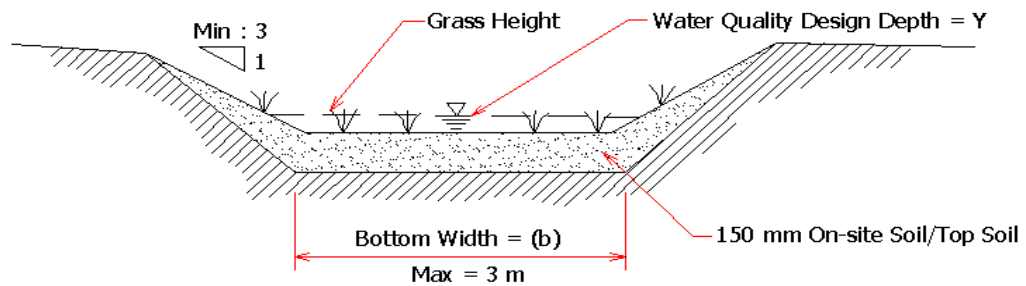

(a) Typical Section

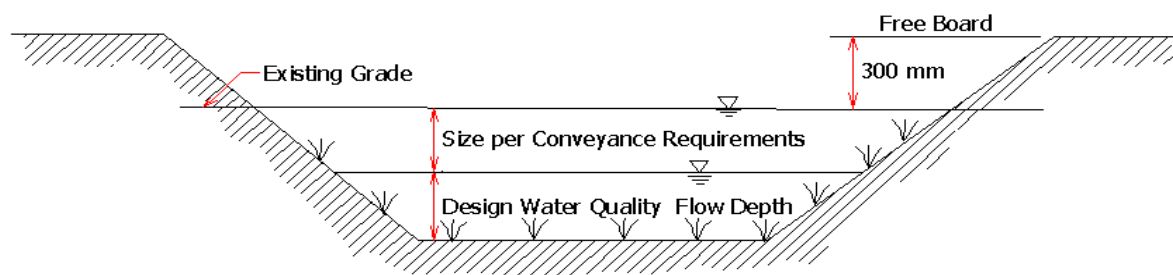

(b) Design Requirements

Figure 31.2 Biofiltration Swale

5. Divert runoff during the period of construction or/and vegetation establishment. Turfing is an alternative when rapid establishment must occur. Where runoff diversion is not possible, cover graded and seeded areas with a suitable erosion control slope covering material (see Chapter 39).
6. Prevent bare areas in biofilters by avoiding gravel, rocks and clay hardpan near the surface; fertilising, watering and replanting as needed and ensuring effective drainage. Fertiliser must only be used at an application rate and formula which is compatible with plant uptake and in relation to soil type. For example, high application rates of nitrogenous fertiliser in very permeable soils can result in leaching of nitrate into ground water.
7. Attempt to avoid compaction during construction. If compaction occurs, till or rake before planting to restore lost soil infiltration capacity.

(ii) Specific Design Consideration

1. Biofiltration swales shall be designed for hydraulic capacity, stability and water quality treatment. Base the capacity design for biofiltration swale on the vegetation height equal to the design flow depth and the 3 month ARI design storm. Unless runoff from large events will bypass the swale, base the capacity design for flood passage on the 100 years ARI, plus 300 mm freeboard.
2. Base the design on a trapezoidal cross-section for ease of construction. A parabolic shape will evolve over time. Make side slope no steeper than 3:1 (horizontal:vertical). For mechanical mower, 4:1 is recommended for safety reason.
3. Provide a minimum length of 60 m of swales, using a wide-radius curved path, where land is not adequate for a linear swale (avoid sharp bends to reduce erosion or provide for erosion protection). If a shorter length must be used, increase swale cross-sectional area by an amount proportional to the reduction in length below 60 m, in order to obtain the same water residence time.
4. Install log or rock drop structures approximately every 15 m, if longitudinal slope exceeds 4 percent. Adjust check dam spacing in order not to exceed 4 percent slope within each channel segment between drop structures.
5. Below the design water depth, install an erosion control blanket, at least 100 mm of topsoil and the selected biofiltration seed mix. Above the design water line, use an erosion control seed mix with straw mulch or turf.

(iii) Swale Sizing

The following factors should be considered when sizing swales:

1. water quality treatment
2. capacity for flood flows
3. safety
4. erosion protection

These factors are discussed in turn below. The calculations may require some iteration before all the conditions are satisfied.

(1) Water Quality Treatment

The first sizing calculations are to check flow velocity, depth and residence times during smaller storms. The 3 month ARI flow may be adopted as a reasonable figure in the absence of a thorough performance analysis. For this storm the flow velocity and depth should be calculated using the Manning's n from Table 31.2 and Figure 31.3. Well established vegetation can be assumed. The velocity should be less than 0.5 m/s to avoid flattening of the vegetation, however, lower velocities are preferable. The flow depth should be such that the water depth is less than the grass height.

The minimum residence time is 2 minutes and the minimum swale length of 60 m is recommended. Clearly a longer swale for a given flow will provide better treatment. An alternative approach is to base the length on the residence time of flow in the swale at the design storm flow. The residence time is 2 minutes for traversing a 60 m swale at 0.5 m/s.

(2) Capacity for Flood Flows

The channel must be large enough to contain the maximum design flood flow, unless provision is made to route this flow away from the swale (in some cases large flows may be routed through an alternative flood channel or pipe system). Maximum design flood flows (Q_d) are calculated according to the procedure in Chapter 14. The flow depth and velocity in the channel are then calculated according to:

$$Q_d = AV \quad (31.1)$$

and the Manning's formula:

$$V = \frac{R^{2/3} S_o^{1/2}}{n} \quad (31.2)$$

where A is the flow cross-sectional area, R is the hydraulic radius, S_o is the swale slope and n is the Manning roughness value (see Chapter 26).

The hydraulic radius, R and flow cross-section, A , are functions of the flow depth and flow geometry (see Figure 31.4). Usually a trapezoidal section will be chosen, which may develop into a parabolic shape with time. Triangular cross-sections are not recommended as flow can become channelised in the bottom with lesser contact with vegetation. Maximum recommended side slope is 1:3 (H:V) for vegetated slopes, although flatter slopes are required for mowing. Steeper slopes may be used if protection, such as geotextile, is incorporated into the design.

The flow retardance class and Manning's roughness (n) value can be estimated from the grass cover and height. Manning's roughness values were developed on the basis of extensive tests conducted by the U.S. Soil Conservation Service. For application, first the flow retardance class is estimated from Table 31.2. For the flood calculations a good stand of high vegetation should be assumed as this will provide the highest likely flow resistance and flow depth.

Once the flow retardance class has been determined, the Manning's n , velocity and depth can be determined. To start the calculations, a value of $n=0.1$ can be used in Manning's formula to calculate V and R . Figure 31.3 is then entered to determine a new n . Using Manning's

formula a new V and R are calculated and so on. By iteration, the correct V, R and n can be obtained.

Table 31.2 Guide for Selection of Flow Retardance Class (U.S.SCS, 1985)

Stand	Average Length of Grass (mm)	Flow Retardance Class
Good	> 750	A - Very High
	310 – 610	B - High
	150 – 250	C - Moderate
	50 – 150	D - Low
	< 50	E - Very Low
Fair	> 750	B - High
	310 – 610	C - Moderate
	150 – 250	D - Low
	50 – 150	D - Low
	< 50	E - Very Low

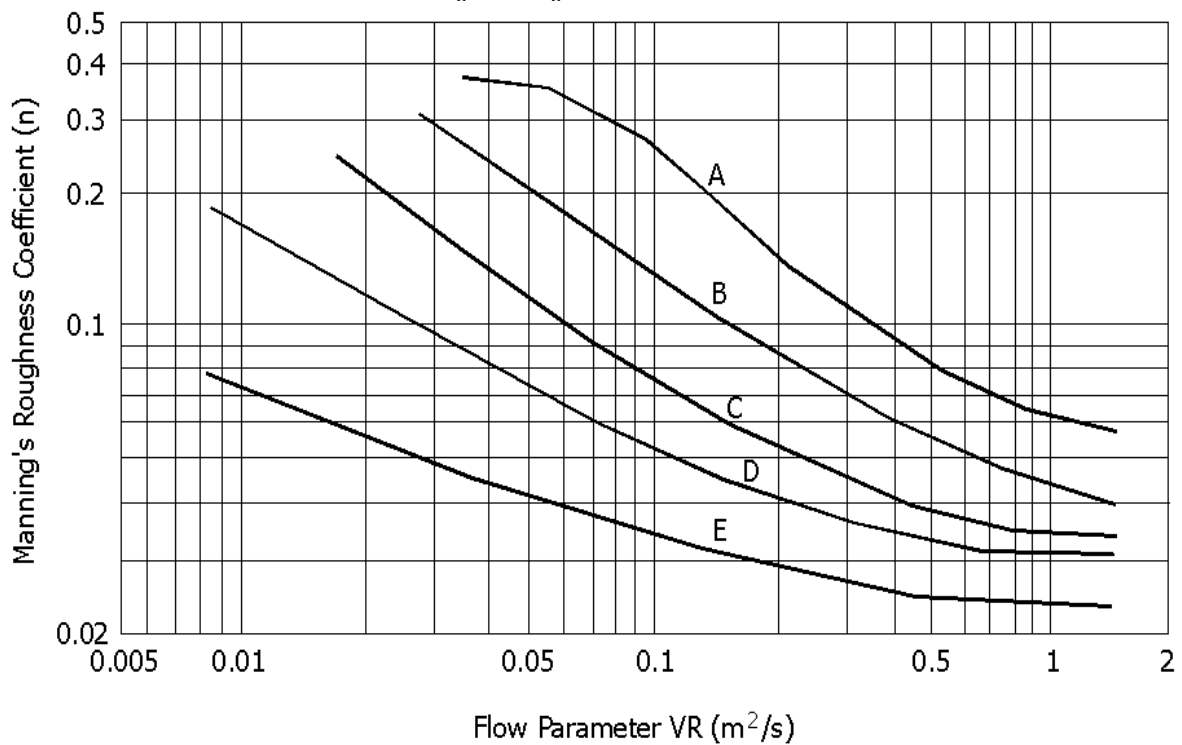
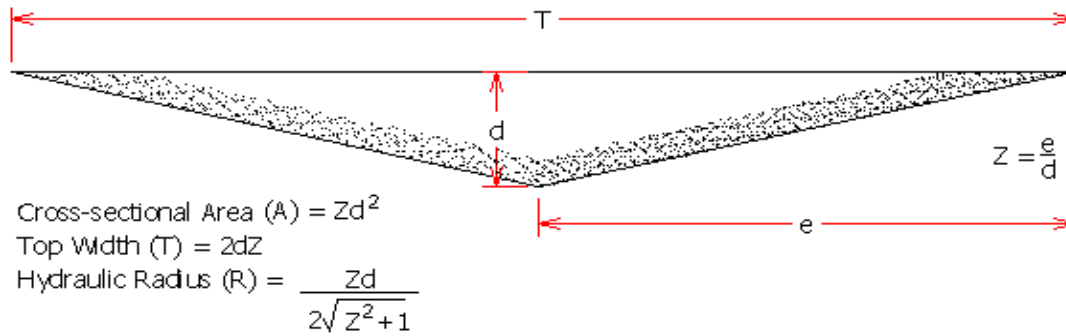

Figure 31.3 Resistance of Grasslined Channels. Curves are Given for 5 Resistance Classes, Determined from Table 31.2 (Source: U.S. Soil Conservation Service, 1985)

CHANNEL GEOMETRY

V-Shape



Parabolic Shape

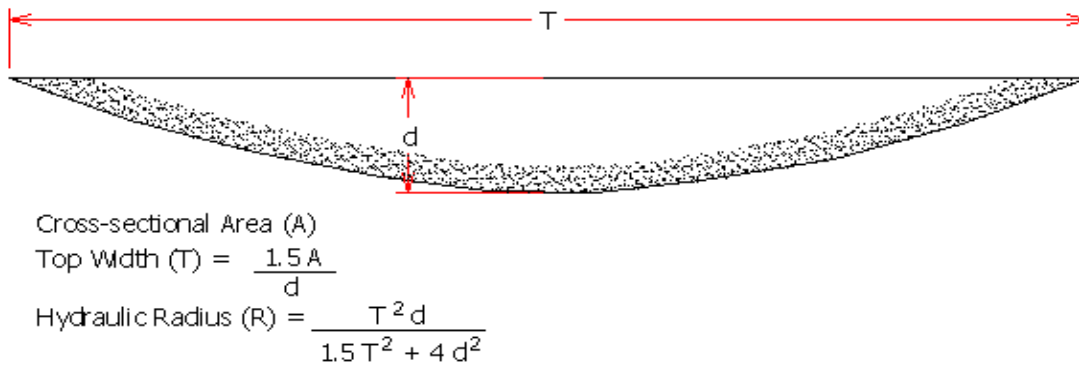

Trapezoidal Shape

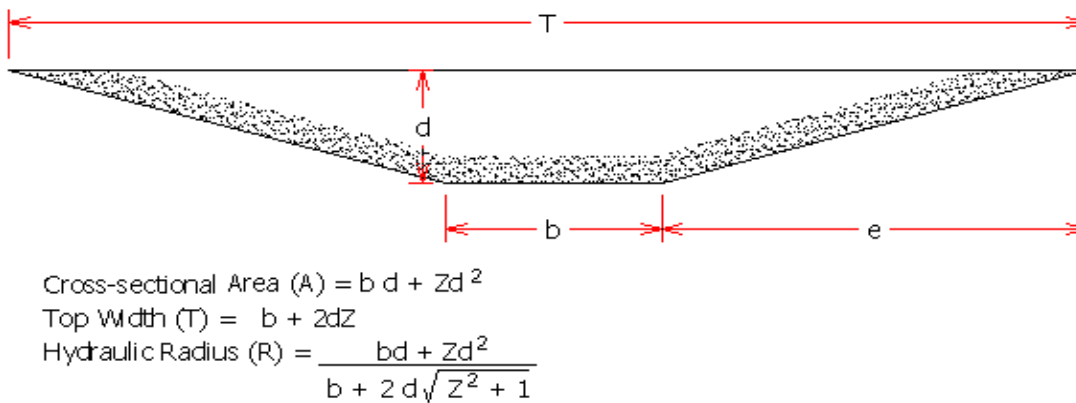

Figure 31.4 Cross-section and Hydraulic Radius for a Swale (U.S. Soil Conservation Service, as Reported in Department of Environmental Regulation, Florida, 1988).

(3) Safety

The safety of children and adults wading in the swale should be considered. Keller and Mitsch (1992) give design values for safety of children. The safety criterion is expressed in terms of VD, the product of the flow velocity in m/s and the depth in meters. The design values range from $VD = 0.2 \text{ m}^2/\text{s}$ at $D = 0.075 \text{ m}$ to $VD = 0.35 \text{ m}^2/\text{s}$ at $D = 0.42 \text{ m}$. For adults, a more appropriate value of VD is $0.4 \text{ m}^2/\text{s}$. These values should be achieved during the mean annual flood and consideration should also be given to achieving these values during less frequent floods.

(4) Erosion Protection

Once the maximum flood depth calculations have been performed and safety has been considered, erosion protection calculations should be performed. For example, the 5 year ARI event, the flow velocities are required to be less than 1.5 m/s although higher velocities may be allowed if erosion protection is provided.

The flow retardance class should be based on the grass conditions when flow is first passed through the swale or when the grass has just been mown. At this stage the flow will be highest and the swale will be most prone to erosion. A typical value of n will be 0.035. Table 31.2 and Figure 31.3 can be used to refine this value.

31.2.3 Vegetated Filter Strip Design

A vegetation filter strip is designed to provide runoff treatment of conventional pollutants as well as nutrients. A vegetated filter strip should not be used for conveyance of larger storms because of the need to maintain sheet flow conditions, plus the filter strip would likely be large for this application.

Vegetated filter strips can be effective at pre-treating runoff to protect infiltration and filtration facilities from siltation. It may also be a viable treatment BMP for small, less intensely developed sites. The maximum recommended drainage flowpath for a vegetated filter strip is 50 m and the flow depth of less than 25 mm for water quality purposes. Vegetated filter strips must not receive concentrated flow discharges as their effectiveness will be destroyed plus the potential for erosion could cause filter strips to become sources of pollution (Figure 31.5)

(a) Design Criteria

An interim criteria have been selected to ensure that a minimum residence time of 5 minutes for the water as it flows across (perpendicular to) the strip. Complete details of the criteria are given below and the appendices give step-by-step procedure for designing strips and swales including an example calculation.

1. Design vegetated filter strips according to the method that the design flow depth (y) will normally be no more than 25 mm because of the need to maintain sheet flow over the strip.
2. The necessary length (parallel to flow) to produce a water residence time should be at least 5 minutes.
3. Install a flow spreader across the top of the strip or make use of a kerb in a parking lot. Make provisions to avoid flow bypassing the filter strip.
4. Vegetated filter strips should not be used for slopes in excess of 10%, because of the difficulty in achieving the necessary sheet flow conditions.

(b) Specific Design Considerations

(i) Flow Distribution

Even flow distribution over the strip is necessary. For this reason the top of the strip should be aligned along a contour line. Flow spreaders such as kerbs or nibs with slots distributed over the length may be useful for flow distribution, as may a gravel-filled trench at the top of the strip.

(ii) Maximum Slopes

Vegetated filter strips should not be used on slopes greater than about 15 percent because of the difficulty in maintaining the necessary sheet flow conditions. Note: This does not mean that vegetated buffers are not suitable for slopes greater than 15 percent; it simply means that effective treatment of runoff is unlikely for slopes greater than 15 percent. Do not confuse a "buffer zone", which is used to protect stream and other environmental resources, with a "vegetated filter strip", which is a runoff treatment BMP.

(iii) Range of Plant Material

A wide range of plant material could be used in filter strips from grasses as discussed in swales and other wet tolerant ground covers through to shrubs and trees. Relatively short (35 mm) grass can be used in relation to the grass used in swales since flow depths over the filters are generally small.

The key feature is a well developed ground cover. This will improve the efficiency of the filter strip and will help promote "sheet flow" and prevent channelling.

(iv) Topsoil

100 mm of good quality topsoil is required on all the filter strip areas, to help develop a good ground cover. Topsoil should be rotary hoed to a medium tilt before turfing.

(c) Sizing

The main sizing consideration is that the flow should be retained in the filter strip long enough to effect the desired removal for the design storm. Unfortunately there is little clear guidance in the literature as to appropriate residence times in the strips.

The State of Maryland Department of Environment (1984) and Schueler (1987) recommend a minimum filter strip length (parallel to flow) of 6 m in cases where the flow passes to another treatment device. The Washington

State Department of Ecology (1990) requires a length sufficient to provide a residence time of 20 minutes in the filter strip for a 6 month storm. Schueler (1987) reports that strips with lengths of 30 m to 90 m are probably needed for adequate removal of the smaller size sediments. Schueler (1987) recommends that the filter strip be as long as the contributing runoff area. It is apparent that there is no clear guidance as to appropriate lengths of filter strips.

For Malaysia the recommended minimum residence time for water quality treatment in the strip is about 5 minutes for the 3 month ARI.

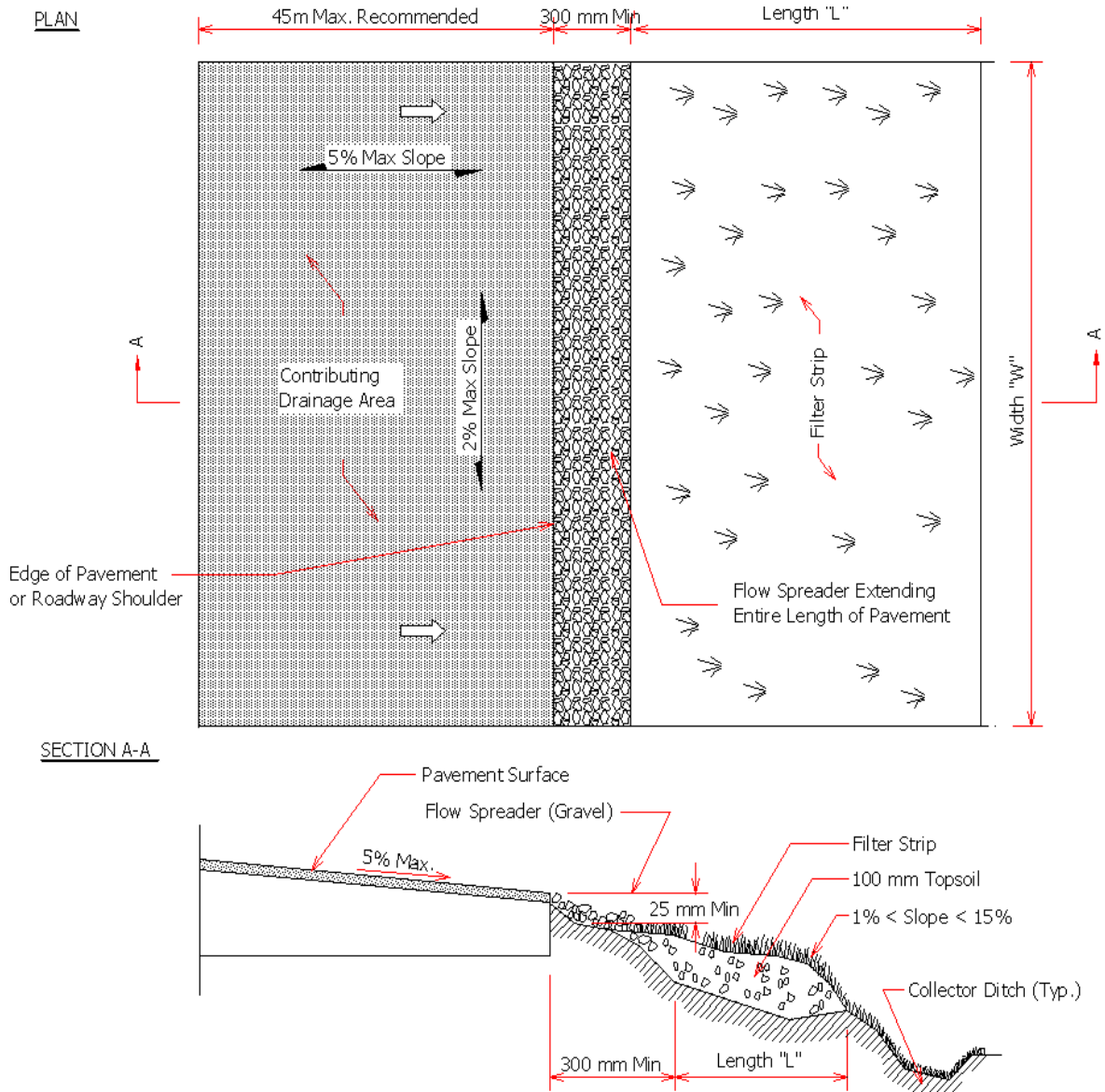

Figure 31.5 Plan and Cross Section of Typical Vegetated Filter Strip

An estimate of the flow velocity for a given flow can be obtained from Manning's equation. There is little guidance on appropriate resistance values (Manning's n values) for small flow depths and velocities. An n value of 0.2 is recommended for dense grass. For calculation of flow depth (Y) and velocity (V), the following equations are used:

$$q = VY \quad (31.3)$$

$$V = \frac{Y^{2/3} S_o^{1/2}}{n} \quad (31.4)$$

$$Y = \left(\frac{qn}{S_o^{1/2}} \right)^{3/5} \quad (31.5)$$

$$q = \frac{Q}{W} \quad (31.6)$$

where S_o is the swale slope, Q is the flow over the strip, q is the flow per unit width of the strip (m^2/s) and W is the width of the strip (perpendicular to the flow direction).

The residence time (t) is calculated according to:

$$t = \frac{L}{V} \quad (31.7)$$

where L is the length of the filter strip (parallel to the flow direction).

The stormwater quality benefits of filter strips within a catchment can be expressed as an effective Water Quality Volume. This effective volume allows a reduction in the size of the device, which follows the filter strip (to achieve the required degree of treatment).

31.2.4 Maintenance

The section shall be used for both BMPs

- Groomed biofilters planted in grasses must be mowed regularly to promote growth and pollutant uptake. Be sure not to cut below the design flow (maintenance personnel must be made aware of this requirement). Remove chipping promptly and dispose in a way so that no pollutants can enter receiving waters.
- If the objective is prevention of nutrient transport, mow grasses or cut emergent wetland-type plants to a low height at the end of the growing season. For other pollution control objectives, let the plants stand at a height exceeding the design water depth by at least 50 mm at the end of the growing season.
- Remove sediments when they build up to 150 mm at any spot, cover biofilter vegetation, or otherwise will

interfere with biofilter operation. If the equipment leaves bare spots, re-seed them immediately.

- Inspect biofilters periodically, especially after periods of heavy runoff. Remove sediments, fertilise and reseed as necessary. Be careful to avoid introducing fertiliser to receiving water or ground water.
- Clean kerb cuts when soil and vegetation build-up interferes with flow introduction.
- Perform special public education for residents near biofilters concerning their purpose and the importance of keeping them free of lawn debris and/or rubbish.
- See that litter is removed in order to keep biofilters attractive in appearance.

31.3 MEDIA FILTRATION

31.3.1 Features and Planning

Sand filtration basins are open impoundments, which filter runoff through a layer of sand into an underdrain system. Sand filtration provides runoff treatment, but not quantity control and these basins are to be located off-line from the primary conveyance/detention system. While effective at treating conventional pollutants, sand filtration is not effective at removing nutrients. Its use for treating oil is being allowed on an interim basis and sand filtration may substitute for oil/water separators (Chapter 33).

The sand bed filtration system consists of an inlet structure, sand bed, underdrain piping and basin liner. The basin liner will only be required if the treated runoff is not to be allowed to percolate into the soil underlying the filtration basin. A liner would be necessary if the filtered runoff required additional treatment, such as in a wet pond for further nutrient removal, or in cases where additional ground water protection was mandated. Figure 31.6 illustrates sand filtration basin systems.

To improve the effectiveness of sand filtration basins and to protect the media from clogging, these basins are to be located off-line from the primary conveyance/detention system and must be preceded by a pretreatment BMP. Disturbed areas that are sediment sources in the contributing drainage should be identified and stabilised to the maximum extent practicable. Because of the potential for clogging, sand filtration BMPs must never be used as sediment basins during construction.

If a sand filtration basin is used as a substitute for an oil/water separator, then pretreatment may not be necessary if the contributing drainage area is small and completely impervious (the restrictions which apply to oil/water separators will also apply to sand filtration basins in this case – see Chapter 31 for further details).

PLAN**SECTION**

Figure 31.6 Sand Filtration Basin Preceded By Presettling Basin

31.3.2 Design Criteria

Sand filtration BMPs are to be designed according to the procedure described in Chapter 12 and 19.2, using the Darcy's Law approach. Important design considerations are discussed below.

(a) Off-line Isolation/Diversion Structure

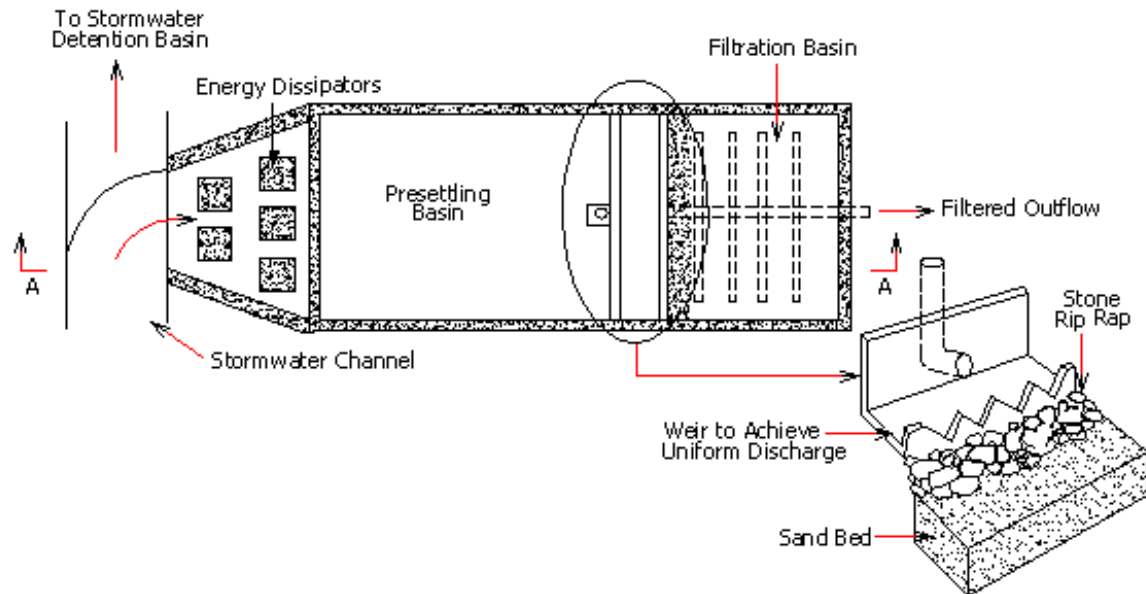
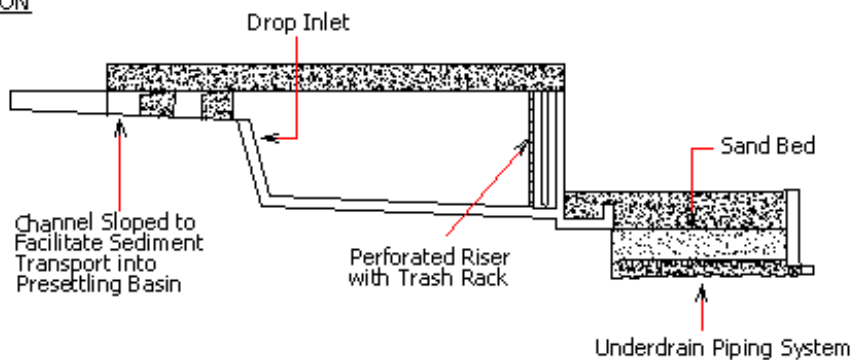
By locating sand filtration systems off-line from the primary conveyance/detention system the long-term effectiveness of the treatment system can be maintained. Off-line systems are designed to capture and treat the 3 month

storm; this is typically achieved by using isolation/diversion baffles and weirs. A typical approach for achieving isolation of the water quality volume is to construct an isolation/diversion weir in the stormwater channel such that the height of the weir equals the maximum height of water in the filtration basin during the 3 month ARI water quality design storm. When additional runoff greater than the water quality design storm enters the stormwater channel, it will spill over the isolation/diversion weir and mixing with already-isolated water quality volume will be minimal. Figure 31.7 illustrates a suitable isolation/diversion structure for an open drain; similar principles can be applied to pipes.

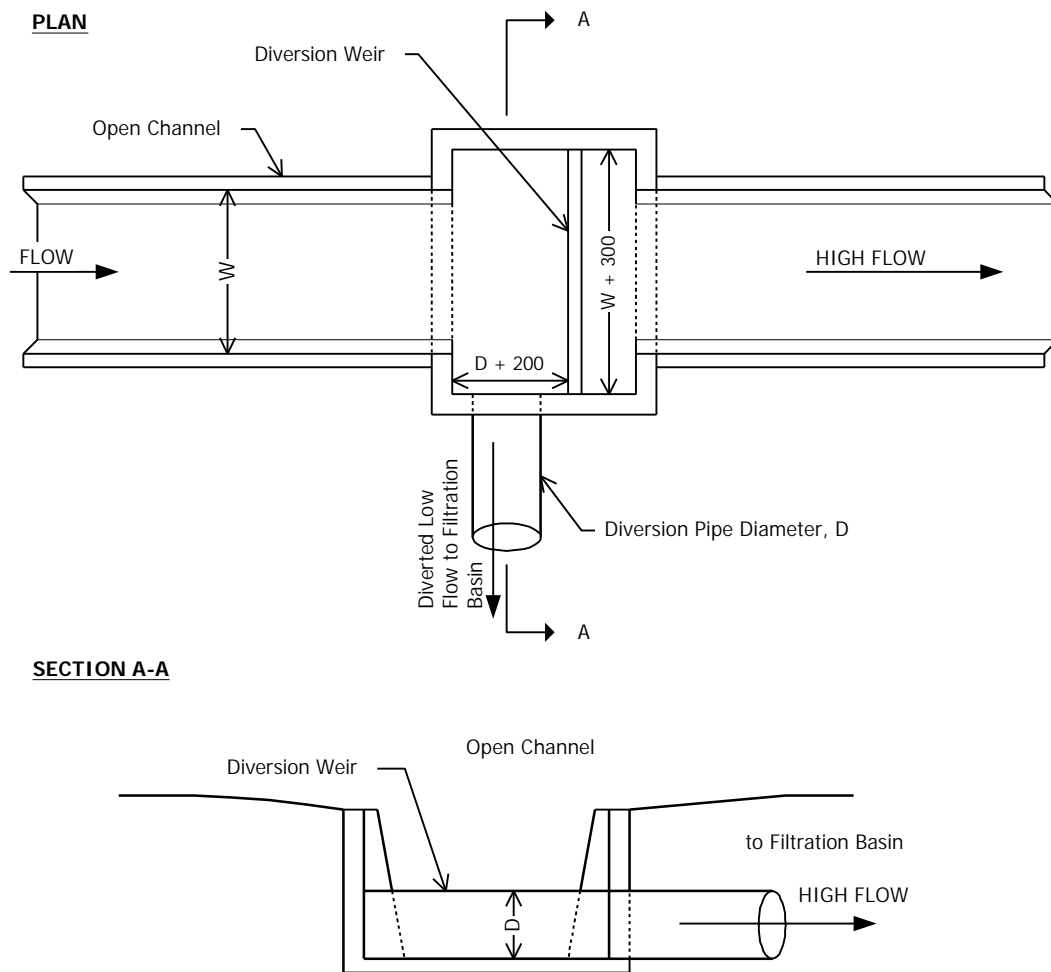

Figure 31.7 Typical Isolation/Diversion Structure

(b) Infiltration Rate

A conservative value for the filtration rate (f) should be used. Design filtration rates of about 50 mm/hr are recommended, which are much lower than published values for sand but reflect actual field permeability rates. The lower rates reflect the effects of suspended solids and sediment on the sand's permeability.

(c) Drainage Area

A maximum contributing drainage area of 5 ha is recommended for sand filtration basins.

(d) Drawdown Time

Sand filtration basins are to be designed to completely empty (drawdown time) in 24 hours or less, so that they will be ready to receive flow from the next storm.

(e) Sizing

Sizing is to be based on Darcy's Law.

Sizing is determined from the two criteria of

- capturing the 3 month ARI storm
- Drawing down and emptying the captured volume

The required surface area of the filter bed is computed from the following equation:

$$A_{df} = \frac{V_w d_f}{f (h_f + d_f) T_f} \quad (31.8)$$

where V_w (m^3) is design volume that enters the filtration device, d_f is the filter bed depth (m), f is the infiltration rate of the filter media (m/hr), h_f is average height of

water above the filter bed (m) and T_f is the design filter bed drain time (hr).

Water depth above the filter should not exceed 2m.

(f) *Inlet Structure*

The inlet structure should spread the flow uniformly across the surface of the filter media. Flow spreaders, weirs or multiple orifice opening are recommended. Stone riprap or other dissipation devices should be installed to prevent gouging of the sand media and to promote uniform flow.

(g) *Sand Bed*

A minimum sand bed depth of 500 mm is recommended. This is the final bed depth, which includes consolidation of the sand during construction.

Two sand bed configurations can be selected from; one with a gravel layer and the other a trench design which utilises drainage matting as a substitute for the gravel layer. The top surface layer should be level so that equal distribution of runoff will be achieved in the basin.

(i) *Sand Bed with Gravel Layer (Figure 31.8)*

Top layer is to be minimum of 500 mm of 0.5 – 1.0 mm diameter sand (smaller sand size is acceptable). Under the sand shall be a layer of 12 mm to 50 mm diameter gravel, which provides a minimum of 50 mm of cover over the top of the underdrain lateral pipes. No gravel is required under the lateral pipes. The sand and gravel must be separated by a layer of geotextile fabric.

(ii) *Sand Bed with Trench Design (Figure 31.9)*

This configuration can be used on flatter sites, which may restrict the applicability of the previous design. The top layer shall be 300–500 mm of 0.5-1.0 mm diameter sand (300mm to the gravel layer, 500mm to the trench bottom). Laterals shall be placed in trenches with a covering of 12 mm to 50 mm gravel and geotextile fabric. The lateral pipes shall be underlain by a layer of drainage matting. The geotextile fabric is needed to prevent the filter media from infiltrating into the lateral piping. The drainage matting is needed to provide adequate hydraulic conductivity to the laterals.

(h) *Underdrain Piping*

The underdrain piping consists of the main collector pipe (and perforated lateral branch pipes). The piping should be reinforced to withstand the weight of the overburden. Internal diameters of lateral branch pipes should be 100 mm or greater and perforation should be 12 mm. The maximum spacing between laterals should be 3 m. Lesser spacings are acceptable. The maximum spacing between rows of perforations should not exceed 150 mm.

The minimum grade of piping shall be 0.5% slope. Access for cleaning all underdrain piping is needed; this can be provided by installing cleanout ports, which tee into the underdrain system and surface above the top of the sand filtration media.

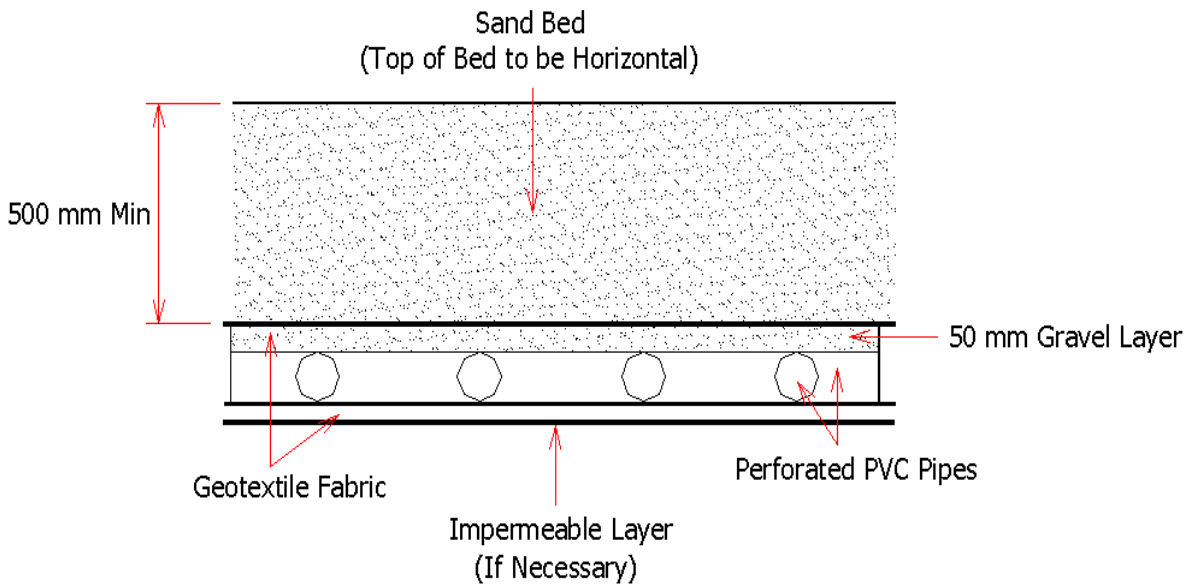

Figure 31.8 Sand Bed Profile with Gravel Layer

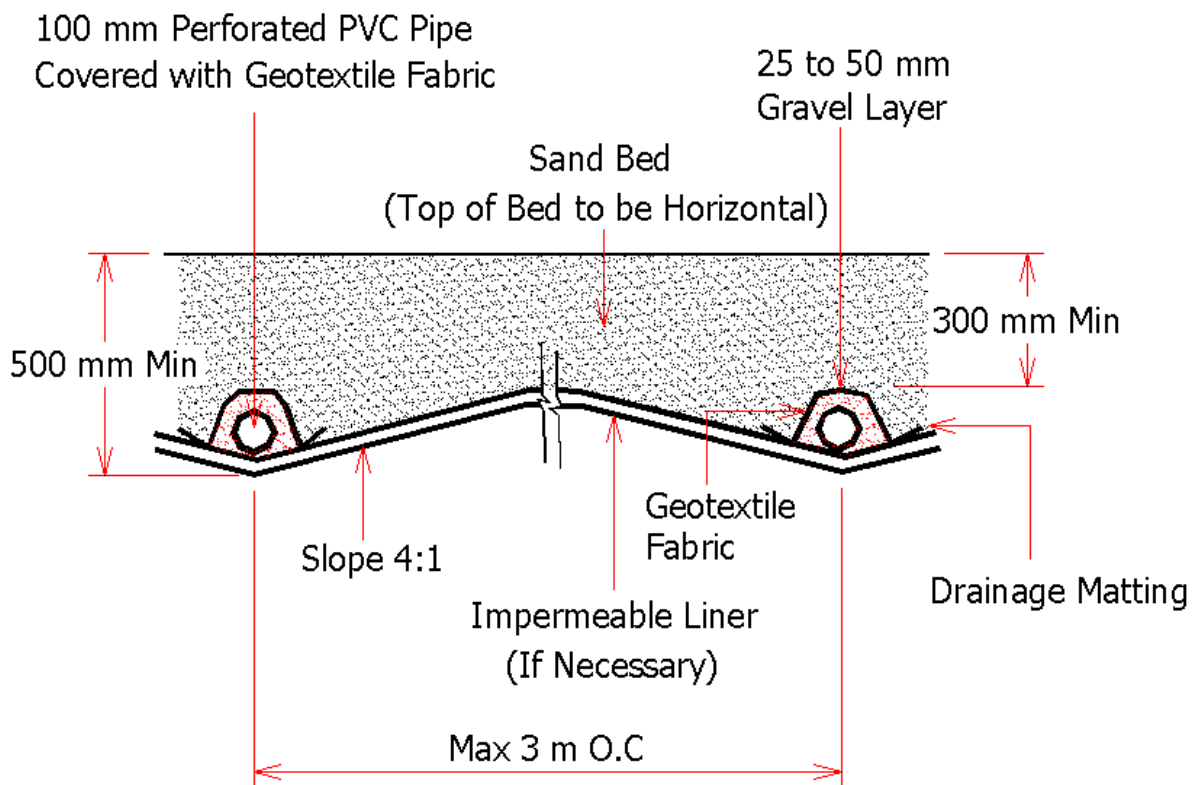

Figure 31.9 Sand Bed Profile with Trench Design (Source : City of Austin, 1988)

(i) Basin Liner

If an impermeable liner is required, clay liner, concrete or geomembrane can be used. If an impermeable liner is not required then a geotextile fabric liner shall be installed unless the basin has been excavated to bedrock. The clay liner should have a minimum thickness of 300 mm.

If a geomembrane liner is used instead of clay, it should have a minimum thickness of 30 mils and be ultraviolet resistant. The geomembrane fabric should be protected from puncture, tearing, and abrasion by installing geotextile fabric on the top and bottom of the geomembrane.

Equivalent methods for protection of the geomembrane liner will be considered. Equivalency will be judged on the basis of ability to protect the geomembrane from puncture, tearing, and abrasion.

Concrete liners may also be used for sedimentation chamber and for sedimentation and filtration basins less than 100 m² in area. Where visible, the concrete shall be inspected annually and all cracks shall be sealed.

(j) Pretreatment

It is recommended that a presettling basin and/or biofiltration swale be used to pretreat runoff discharging to the sand filter. Descriptions of these two BMPs are provided in Section 31.2, respectively.

If a presettling basin is used for pretreatment, careful attention must be given to designing the inlet and outlet structures. The presettling basin consists of an inlet structure, outlet structure and basin liner if permeable soils underlay the basin. The presettling basin design should maximise the distance from where the heavier sediment is deposited near the inlet to where the outlet structure is located. This will improve basin performance and reduce maintenance requirements.

- Inlet Structure – The inlet structure design must be adequate for isolating the water quality volume from the larger design storms and to convey the peak flows for the larger design storms past the basin. The water quality volume should be discharged uniformly and at low velocity into the presettling basin in order to maintain near quiescent conditions, which are necessary for effective treatment. It is desirable for the heavier suspended material to drop out near the front of the basin; thus a drop inlet structure is

recommended in order to facilitate sediment removal and maintenance. Energy dissipation devices may be necessary in order to reduce inlet velocities, which exceed 1.0 m/s.

- **Outlet Structure** – The outlet structure conveys the water quality volume from the presettling basin to the filtration basin. The outlet structure shall be designed in conjunction with the sand filter to provide for a residence time 24 hours for the 3 month storm. See Chapter 33 for calculating residence time. A perforated pipe or equivalent is the recommended outlet structure. The residence time should be achieved by installing a throttle plate or other flow control device at the end of the riser pipe (the discharges through the perforations should not be used for drawdown time design purposes).

A trash rack shall be provided for the outlet. Opening in the rack should not exceed $\frac{1}{2}$ the diameter of the vertical riser pipe. The rack should be made of durable material, resistant to rust and ultraviolet rays. The bottom rows of perforations of the riser pipe should be protected from clogging. To prevent clogging of the bottom perforations it is recommended that geotextile fabric be wrapped over the pipe's bottom rows and that a cone of 25 mm to 75 mm diameter gravel be placed around the pipe. If geotextile fabric wrap is not used then the gravel cone must not include any gravel small enough to enter the riser pipe perforations.

The pretreatment BMP may need to have a basin liner to prevent runoff from being lost to soil infiltration prior to treatment by the filtration basin.

31.3.3 Construction and Maintenance Criteria

(a) Construction Requirements

- The erosion and sediment control plan must be configured to permit construction of the pond while maintaining erosion and sediment control. No runoff is to enter the sand filtration basin prior to completion of construction and site revegetation. Construction runoff may be routed to the sediment basin/chamber but outflow from this structure shall by-pass the sand filter basin.
- The final sand bed thickness must be 500 mm; consolidation of sand will likely occur during installation and this must be taken into account.
- Provisions must be made for access to the basin for maintenance purpose. A maintenance vehicle access ramp is necessary. The slope of the ramp should not exceed 4:1.
- The design should minimise susceptibility to vandalism by use of strong materials for exposed piping and accessories.

- Side slopes for earthen embankment should not exceed 4:1 to facilitate mowing.
- Careful level placement of the sand is necessary to avoid formation of voids within the sand that could lead to short-circuiting, (particularly around penetrations for underdrain cleanouts) and to prevent damage to the underlying geomembranes and underdrain systems. Voids between the trench walls and the geotextile fabric should also be avoided.
- Over compaction should be avoided to ensure adequate filtration capacity. Sand is best placed with a low ground pressure bulldozer (30 kN/m² or less).
- After the sand is placed water settling is recommended. Flood the sand with 1.3-2 m³ of water per cubic metre of sand.

(b) Maintenance Requirements

- Removal of silt when accumulation exceeds 12 mm.
- Removal of accumulated paper, trash and debris every three (3) months or as necessary.
- Corrective maintenance is required when the water level over the filter drops at a rate less than 12 mm per hour.
- Annual inspection and as necessary, repair of the structure.
- Rapid drawdown in the filter (greater than 300 mm per hour) indicates short-circuiting of the filter. Inspect the cleanouts on the underdrain pipes and along the base of the embankment for leakage.

(c) Sand Media Rehabilitation and Replacement

Over time, a layer of sediment will build up on top of filtration media, which can inhibit the percolation of runoff. Experience has shown that this sediment can be readily scraped off during periods with steel rakes or other devices. Once sediment is removed the design permeability of the filtration media can typically be restored by then striating the surface layer of the media. Eventually, however, finer sediments, which have penetrated deeper into the filtration media, will reduce the permeability to unacceptable levels, thus necessitating replacement of some or all of the sand. The frequency in which the sand media must be replaced is not well established and will depend on the suspended solids levels entering the system (thus, the effectiveness of the pretreatment BMP can be a significant factor). Drainage areas, which have disturbed areas containing clay soils, will likely necessitate more frequent replacement. Properly designed and maintained sand filtration BMPs should function effectively, without complete replacement of the sand media, for at least five years and should have design lives of 10 to 20 years.

APPENDIX 31.A WORKED EXAMPLE

31.A.1 Biofiltration Swale

Problem: A biofiltration swale is proposed for Sekolah Menengah Kebangsaan Seri Ampang, Ipoh Perak. The catchment area is 2.5 ha comprises of 1.26 ha of impervious area (building and parking) and 1.24 ha of pervious area (playing field and garden).

The following assumptions are made:

Time of concentration, $t_c = 20$ minutes

The slope of the swale, $S = 2\%$

Solution:

Step (1) Determine $Q_{3\text{-month}}$ for the biofiltration swale

Total Area $A = 2.5$ ha

Impervious Area $A_i = 1.26$ ha (category (1) in Design Chart 14.3)

Pervious Area $A_p = 1.24$ ha (category (6) in Design Chart 14.3)

$t_c = 20$ minutes

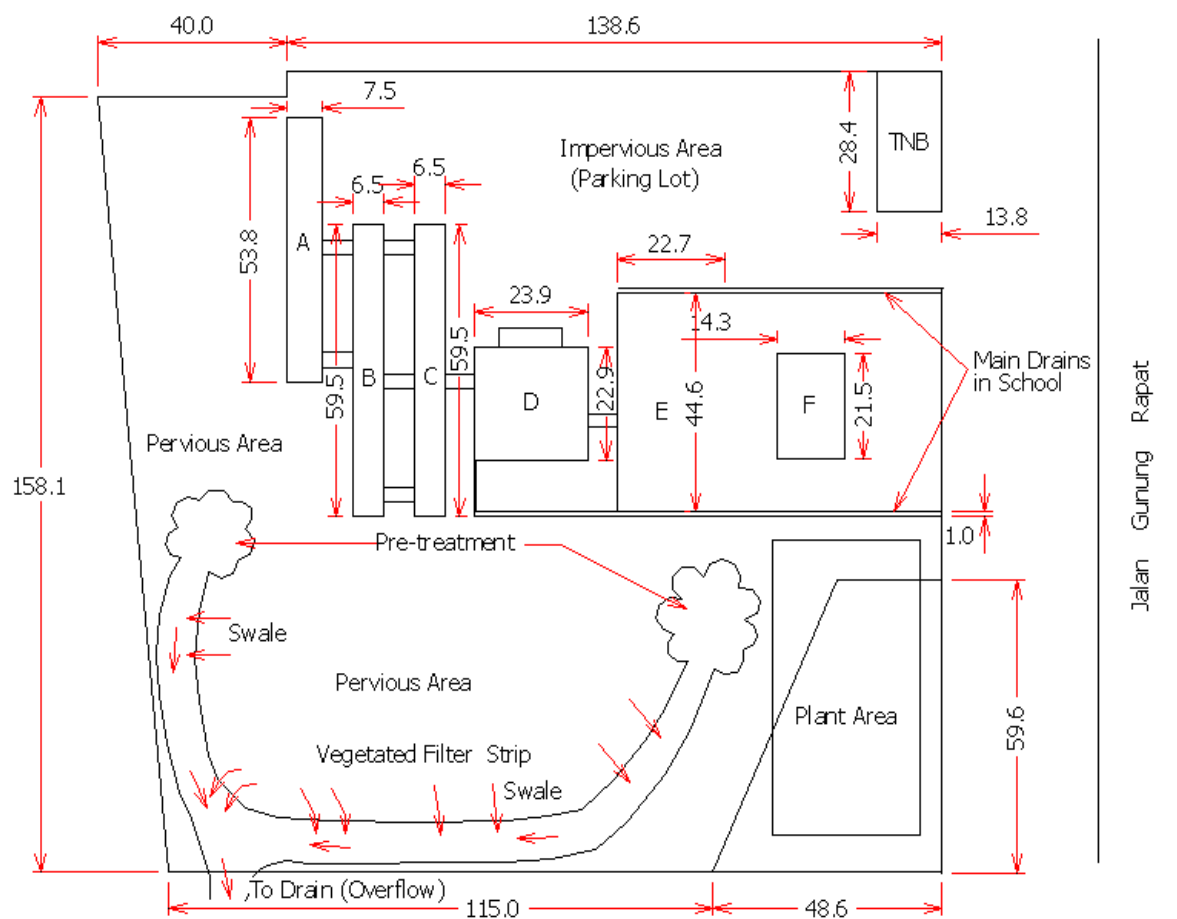

Figure 31.A1 Swale Layout for Sekolah Menengah Seri Ampang at Rapat Setia, Ipoh.

To calculate rainfall intensity (refer Table 13.A1)

$$\ln(I) = a + b\ln(t) + c[\ln(t)]^2 + d[\ln(t)]^3$$

For Ipoh, 2 year ARI and t = 20 minutes

t _c (min)	a	b	c	d	Ln(I)	I (mm/hr)
	5.2244	0.3853	-0.1970	0.0100		
	a	bln(t)	c[ln(t)] ²	d[ln(t)] ³		
	5.2244	1.1543	-1.7680	0.2688	4.880	132

For Ipoh, 5 year ARI and t = 20 minutes

t _c (min)	a	b	c	d	Ln(I)	I (mm/hr)
	5.2244	0.6149	-0.2406	0.012		
	a	bln(t)	c[ln(t)] ²	d[ln(t)] ³		
	5.2244	1.8421	-2.1592	0.3226	5.0062	149

For Ipoh, 10 year ARI and t = 20 minutes

t _c (min)	a	b	c	d	Ln(I)	I (mm/hr)
	5.0707	0.6515	-0.2522	0.0138		
	a	bln(t)	c[ln(t)] ²	d[ln(t)] ³		
	5.0707	1.9517	-2.2633	0.3710	5.1301	169

$${}^2I_{20} = 132 \text{ mm/hr}$$

$$\text{From Equation 13.5c, } {}^{0.25}I_D = 0.5x^2I_D$$

$$\text{Thus, } {}^{0.25}I_{20} = 0.5x132 = 66 \text{ mm/hr}$$

$$\text{Total Area } A = 2.5 \text{ ha}$$

$$\text{Impervious Area } A_I = 1.26 \text{ ha (category (1))}$$

$$\text{Pervious Area } A_P = 1.24 \text{ ha (category (6))}$$

$$\text{Combined } C = 0.9x1.26/2.5 + 0.37x1.24/2.5 = 0.64$$

$$Q_{0.5} = \frac{C \cdot {}^{0.5}I_{20} \cdot A}{360}$$

$$Q_{0.5} = 0.293 \text{ m}^3/\text{s}$$

$$Q_5 = 0.662 \text{ m}^3/\text{s}$$

$$Q_{10} = 0.751 \text{ m}^3/\text{s}$$

Step (2) Determine water quality requirement for biofiltration swale

Say,

$$\text{Slope, } S_0 = 0.03$$

Side Slope, $Z = 3$

Try,

Overland Manning $n = 0.1$ (Grass Class D)

$Y = 0.150$ m (maximum value)

Estimate the bottom width (B) of the swale

$$Q = \frac{AR^{2/3}S^{1/2}}{n} \quad (31.A1)$$

The other equation for trapezoidal swale

$$\text{Cross section area, } A = By + Zy^2 \quad (31.A2)$$

$$\text{Hydraulic radius, } R = \frac{A}{B + 2y\sqrt{Z^2 + 1}} \quad (31.A3)$$

$$\text{Top width, } T = B + Zy^2 \quad (31.A4)$$

If Equation 31.A2 and 31.A3 are substituted into Equation 31.A1 and solved for B, complex equations result that are difficult to solve manually. Approximate solution can be used by recognising that $B \gg y$ and $Z^2 \gg 1$, and that certain terms are nearly negligible. The approximate solution for trapezoidal shape is $R \approx y$,

thus,

$$\text{Bottom width of trapezoidal swale, } B \approx \frac{Qn}{y^{5/3}S^{1/2}} - Zy \quad (31.A5)$$

Note: If B for a swale is greater than 3 meter, either investigate how Q can be reduced, divide the flow by installing a low berm, or arbitrarily set $B = 3$ meter and continue with the analysis

Try B for $Q_{0.25} = 0.293$ m³/s using Equation 31.A5

$B = 4.0$ m, and this is greater than maximum swale width of 3 meter, thus, divide the catchment into two, such that one swale drains/caters runoff from west side and other swale drains/caters the east side. Therefore, the discharge from individual subcatchment become half; $Q_{0.25} = 0.147$ m³/s

For $Q_{0.25} = 0.147$ m³/s, and using Equation 31.A5 $B \approx 2.0$ m

Try $B = 2.0$ m

$A = 0.368$ m²; $R = 0.132$ m

$V_d = 0.49$ m/s (O.K)

Step (3) Check for Capacity for Flood Event

Based on the 10 year ARI, the Q_{10} for the proposed swales is 0.376 m³/s.

Assume Grass Class D and the trial Manning $n = 0.05$ (refer Figure 31.3)

Thus $VR = 0.11$ m²/s

Estimate the depth of flow in the swales, $D = 0.2$ m

$A = 0.52$ m²; $R = 0.16$ m

$V_d = 0.73$ m/s (Equation 31.1)

Using Manning n, determine $V = 1.0$ m/s (Equation 31.2)

The disparity between these velocities means that the trial depth should be smaller.

By trail and error, the new trial depth is 0.167 m.

$$A = 0.415 \text{ m}^2 ; R = 0.136 \text{ m}$$

$$\text{Thus } V_d = 0.91 \text{ m/s, } V = 0.92 \text{ m/s and } VR = 0.12 \text{ m}^2/\text{s}$$

From Figure 31.3 (with $VR = 0.11 \text{ m}^2/\text{s}$) n is 0.05 which agrees with the trial values, so the correct velocity and flow depth have been found.

Step (4) Check for Safety

The flow depth and residence time will now be calculated for the 1 year ARI (mean annual storm) of $0.235 \text{ m}^3/\text{s}$. During this event, the velocity times depth (VD) is 0.096, which is safe for wading children

Step (5) Check for Erosion Protection

Based on the 5 year ARI, the Q_5 for the proposed swales is $0.331 \text{ m}^3/\text{s}$.

The velocity during 5 years ARI, $V_d = 0.81 \text{ m/s}$ which is less than 1.5 m/s, thus erosion is not of concern.

Step (6) Final dimension of the proposed swales for Sekolah Menengah Seri Ampang should have the depth of 0.167 m plus 0.30 m of freeboard (Figure 31.A2)

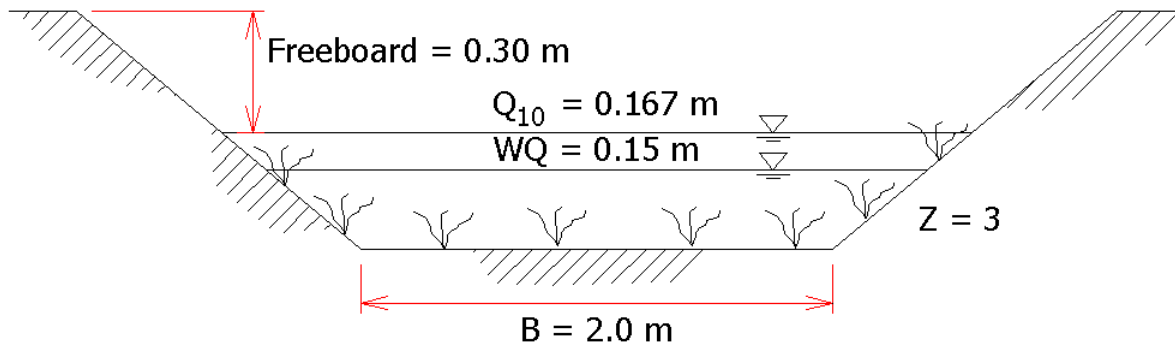

Figure 31.A2 Swale Designed Section

31.A.2 Vegetated Filter Strips

Problem: A vegetated filter strip is proposed beside a parking lot in a shopping complex in Ipoh. Each metre width of the filter accepts from 50 m² of parking lot. The slope of the strip is 2%.

The following assumptions are made:

Time of concentration, $t_c = 10$ minutes

Type of development is impervious area

Solution:

Step (1) Determine $Q_{3\text{-month}}$ for vegetated filter strip

Area per meter width $A = 50 \text{ m}^2 = 0.005 \text{ ha}$

Catchment slope $S = 2\%$

$t_c = 10$ minutes

To calculate rainfall intensity (refer Table 13.A1)

$$\ln(I) = a + b\ln(t) + c[\ln(t)]^2 + d[\ln(t)]^3$$

For Ipoh, 2 year ARI and $t = 10$ minutes

t_c (min)	a	b	c	d	$\ln(I)$	I (mm/hr)
	5.2244	0.3853	-0.1970	0.0100		
	a	$b\ln(t)$	$c[\ln(t)]^2$	$d[\ln(t)]^3$		
	5.2244	0.8872	-1.0445	0.1221	5.1892	179

$${}^2I_{10} = 179 \text{ mm/hr}$$

$C = 0.9$ (category (1) in Design Chart 14.3)

From Equation 13.5c, ${}^{0.25}I_D = 0.5x^2I_D$

Thus, ${}^{0.25}I_{10} = 0.5 \times 179 = 89.5 \text{ mm/hr}$

$$Q_{0.5} = \frac{C \cdot {}^{0.5}I_{10} \cdot A}{360}$$

$$Q_{0.5} = 0.00112 \text{ m}^3/\text{s}$$

Step (2) Determine required length for vegetated filter strip

Assume the $n = 0.2$

From Equation 31.A5, the flow depth (Y)

$$Y = \left(\frac{0.00112 \times 0.2}{0.02^{1/2}} \right)^{3/5}$$

$$= 21 \text{ mm}$$

From Equation 31.2, the velocity (V)

$$V = \frac{0.021^{2/3} \times 0.02^{1/2}}{0.2}$$

$$= 0.053 \text{ m/s}$$

From Equation 31.A7, the required length of vegetated filter strip (L) with minimum residence time (t) of 5 minutes

$$\begin{aligned} L &= 0.053 \text{ m/s} \times 300 \text{ s} \\ &= 16 \text{ metre} \end{aligned}$$

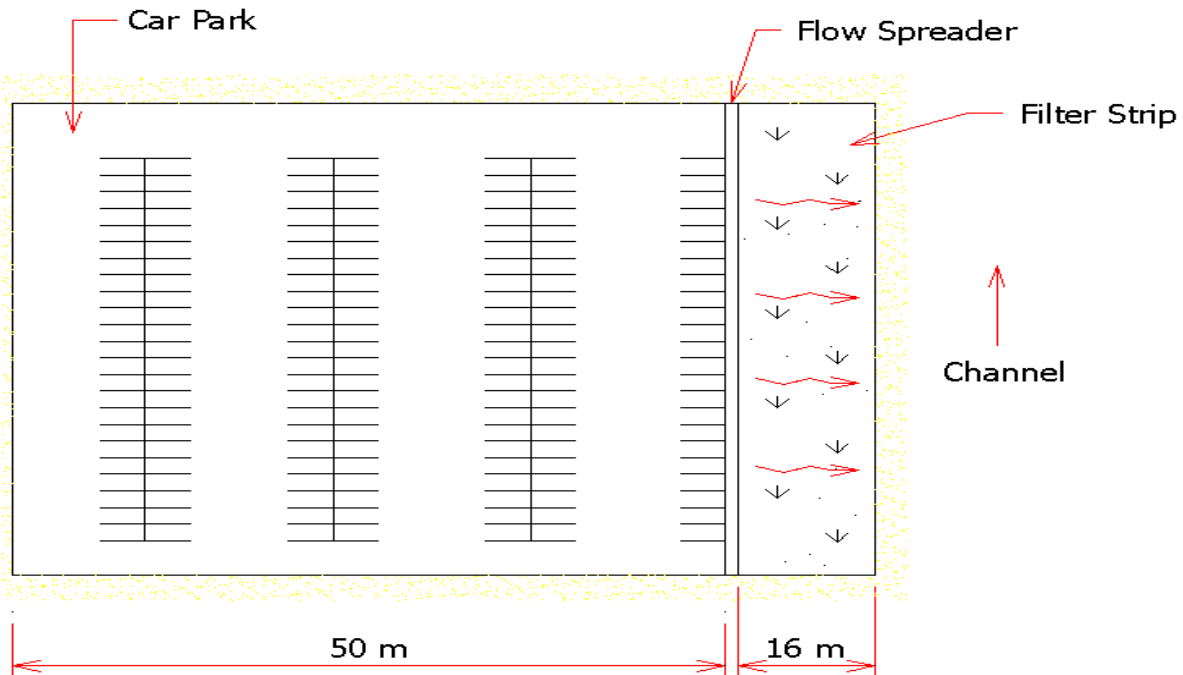

Figure 31.A3 Layout of Example Filter Strip

31.A.3 Media Filtration

A filtration facility is to be designed to receive runoff from a 2000 m² of completely paved parking area in Ipoh. Determine the size of filtration facility required.

- i) Use 3 month ARI, 3 hr storm

$$I = 16.56 \text{ mm/hr}$$

$$\begin{aligned} \text{Volume of flow} &= (16.56)(3)(2000)/1000 \\ &= 99.36 \text{ m}^3 \end{aligned}$$

- ii) $d_f = 500 \text{ mm}$, $f = 50 \text{ mm/hr}$

$$h_f = 0.6 \text{ m}, \quad t_f = 24 \text{ hr}$$

Using Equation (31.1)

$$\begin{aligned} A_f &= (99.36)(0.5)/[(0.05)(0.6+0.5)(24)] \\ &= 37.6 \text{ m}^2 \end{aligned}$$

With length:width ratio of 2,

$$\text{Width} = 4.5 \text{ m} \quad \text{Length} = 9 \text{ m}$$